

NASA's Jet Propulsion Laboratory  
Pasadena, California 91109-8099

# Technical Support Package

May contain Caltech/JPL proprietary information and be subject to export control;  
comply with all applicable U.S. export regulations.

## Ultrafast Processor for Interferometric Radar

NASA Tech Briefs  
NPO-42026



National Aeronautics and  
Space Administration

Technical Support Package  
for  
**ULTRAFAST PROCESSOR FOR INTERFEROMETRIC RADAR**  
**NPO-42026**  
*NASA Tech Briefs*

The information in this Technical Support Package comprises the documentation referenced in **NPO-42026** of *NASA Tech Briefs*. It is provided under the Commercial Technology Program of the National Aeronautics and Space Administration to make available the results of aerospace-related developments considered having wider technological, scientific, or commercial applications. Further assistance is available from sources listed in *NASA Tech Briefs* on the page entitled "NASA Innovative Partnerships Program."

Additional information regarding research and technology in this general area may be found in a variety of publications available from the NASA Scientific and Technical Information (STI) Program Office. You can access the STI Program Office via <http://www.sti.nasa.gov> or as follows:

NASA STI Help Desk  
NASA Center for AeroSpace Information  
7121 Standard Drive  
Hanover, MD 21076-1320

Telephone: (301) 621-0390, Fax: (301) 621-0134,  
E-mail: [help@sti.nasa.gov](mailto:help@sti.nasa.gov)

---

NOTICE: This document was prepared under the sponsorship of the National Aeronautics and Space Administration. Neither the United States Government nor any person acting on behalf of the United States Government assumes any liability resulting from the use of the information contained in this document or warrants that such use will be free from privately owned rights. If trade names or manufacturers' names are used in this report, it is for identification only. This usage does not constitute an official endorsement, either expressed or implied, by the National Aeronautics and Space Administration.

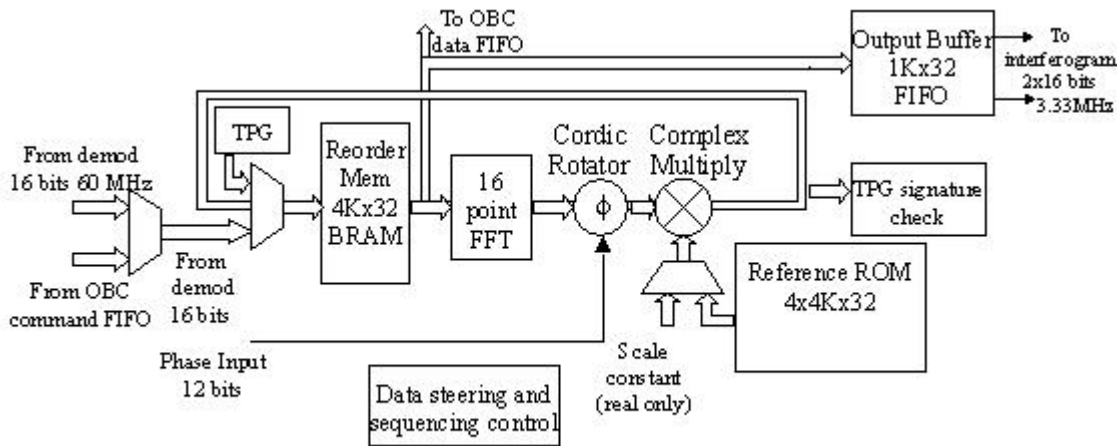

Fig. 1. Fast convolution engine developed for the processor FPGA aboard WSOA. The phase input interface makes it possible to simultaneously perform pulse-compression, time-shift, and frequency-shift operations required for radar interferometry.

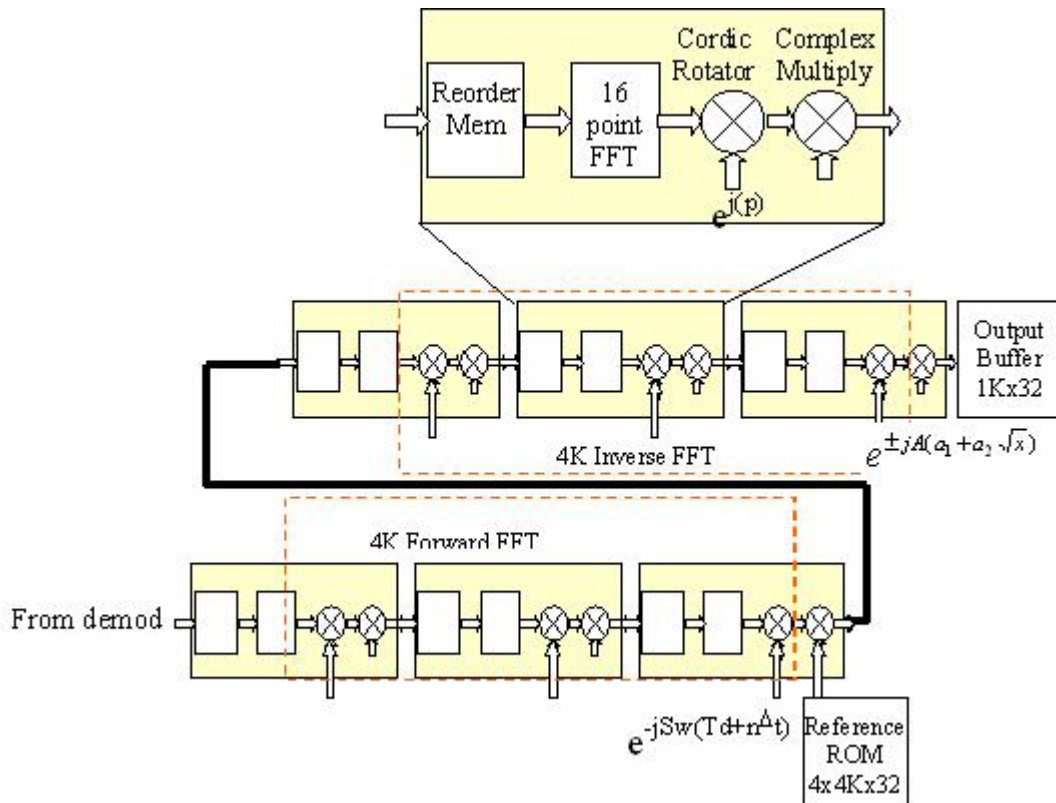

Fig. 2. Convolution function, showing the timeline for running the radar return data through multiple passes of the convolution processing cell.